

FREQUENTLY ASKED QUESTIONS

QUESTION: What is my commitment if I agree to have the HeatMaxx or CoolMaxx test done?

ANSWER: There is no obligation, these tests are done as part of our service program and so that we (and you) can understand your total comfort system better.

QUESTION: What is the cost of the testing?

ANSWER: There's no additional cost for the HeatMaxx and CoolMaxx testing. It's part of our normal service. After the initial testing, we'll present you with preliminary system efficiency information. If there are deficiencies, we can perform more in-depth testing and analysis for a complete picture of what needs to be done to maximize your system's performance.

QUESTION: Does the test disrupt my furnace or air conditioner?

ANSWER: No. We actually perform the test while your system is running under normal operating conditions. We will drill a few harmless test holes in your system, but we'll plug them when we are finished.

QUESTION: Can any contractor perform a HeatMaxx or CoolMaxx procedure?

ANSWER: No. Only NCI certified contractors are authorized by NCI to use the HeatMaxx and CoolMaxx test procedures.



Home Comfort Reports®

Home Comfort Reports® Consumer Information Series is a service of National Comfort Institute, Inc. NCI is the largest training and certification organization in the US in the areas of home comfort diagnostics, air balancing, Indoor Air Quality, combustion efficiency and carbon monoxide safety.

This information series was created to help consumers make informed decisions about their air conditioning and heating system purchases so they can achieve the comfort, safety and performance they desire.



National Comfort Institute, Inc.

P.O. Box 2090

Sheffield Lake, OH 44054

Toll Free: 800-633-7058

www.NationalComfortInstitute.com

Home Comfort Reports®

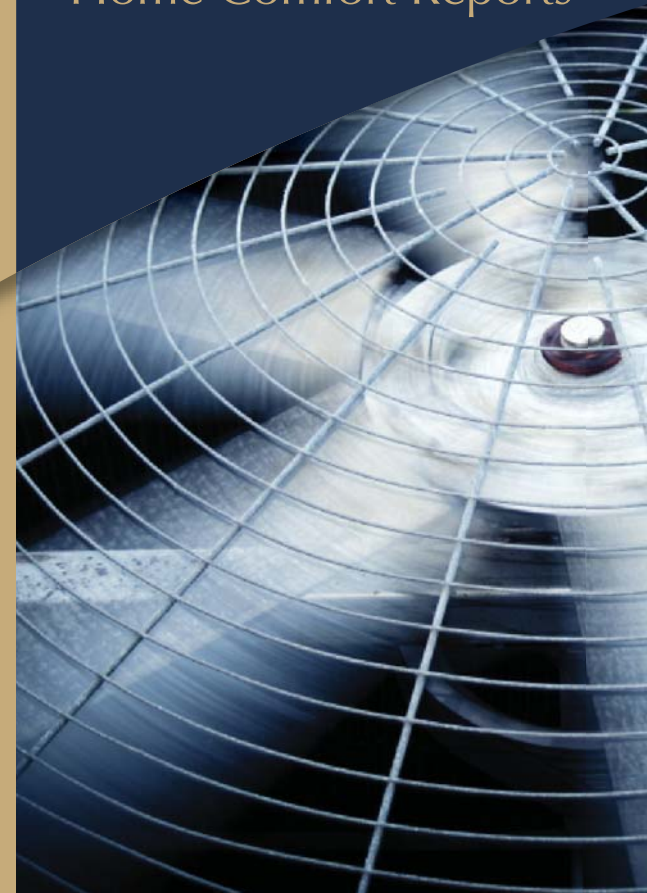

HeatMaxx™ & CoolMaxx™

Comfort System Analysis Service

Your home heating and cooling system may not be delivering the comfort and efficiency you're paying the utility company for.

HeatMaxx and CoolMaxx reports provide a preliminary snapshot of your comfort system's delivered performance.

HeatMaxx™ & CoolMaxx™

Present an Instant Picture of Total Performance

What is a comfort system analysis?

Since the days when we began heating and cooling our homes, service agreements have only included checking the heating and cooling equipment. Until now, our industry has lacked the technology and the skills to include the duct system in your service agreement and measure the operating capacity of your system.

Until recently, when a system didn't work, our only option was to replace the equipment. This often did little to improve system performance. Now we include the duct system and testing system performance as part of our service and are able to diagnose and pinpoint system deficiencies.

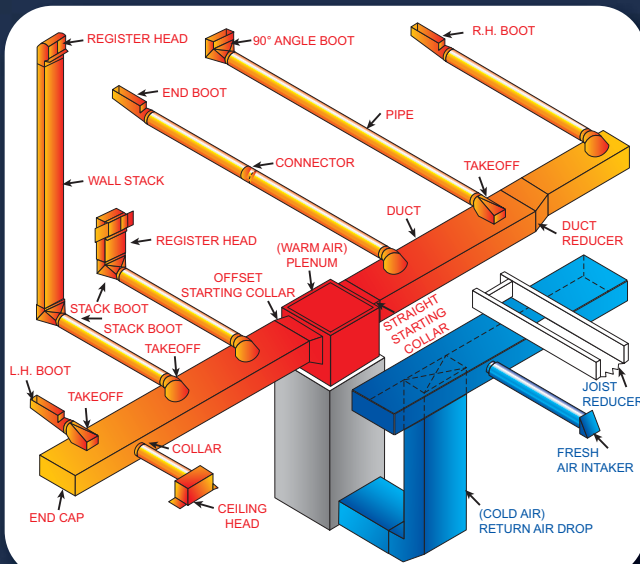

What will these tests tell us?

HeatMaxx and CoolMaxx reports offer a preliminary rating of your heating and cooling system's level of performance. These reports have been created as an air conditioning and heating educational tool for customers of NCI contractors.

Part of our testing includes measuring air pressures in your system. From these tests we can determine the airflow through your system and verify the resistance through your air filters, coil, ductwork and registers. Using this and other data we can calculate the delivered BTUs from your system. High filter pressure, for example, can have a drastic effect on the performance of your system. Other system components can also affect comfort and performance in a similar way.

Think of your duct work as an interstate highway. While all lanes are open the traffic (air) runs smoothly. But with blockage or incorrect flow the traffic (air) backs up and won't heat/cool your rooms properly.

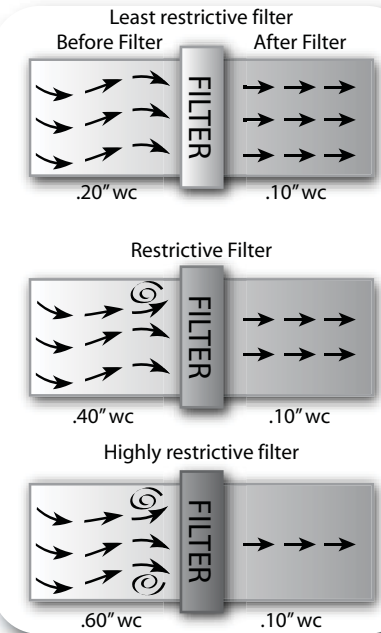

My furnace is brand new; why do I need any analysis?

It's easy to assume that if you have the most recent model of furnace or air conditioner in your home, you should have the most efficient system possible. But unlike a self contained stove or refrigerator, your air conditioning and heating system depends on a series of ducts and registers winding through your home.



HeatMaxx and CoolMaxx rate the live operating efficiency of the entire installed system. This has been previously unavailable to homeowners.

What happens once I get my report?

Your HeatMaxx and CoolMaxx Report is a first step in analyzing your system. If you are happy with your delivered efficiency, no further steps need to be taken. If, however, you find you are only getting 50, 60 or 70 percent of the rated equipment capacity, you may want to have further testing and diagnosis completed to determine how performance can be improved.



Our company is well-equipped to provide you with the testing and knowledge to enable you to make the best decision possible.